

Anchor-Loc® Ceramic Fiber Modules

Introduction

The Anchor-Loc® module system is a family of ceramic fiber module products designed to meet a wide range of application requirements in a variety of heat processing vessels.

Ceramic fiber modules used in the Anchor-Loc systems are constructed with Durablanket® S, Durablanket HP-S, Durablanket 2600, or Fibermax® mat. Each type of Anchor-Loc ceramic fiber module can be easily fastened to interior steel shells of all types of heat processing equipment with several different attachment systems.

The ceramic fiber blanket or mat is secured by two alloy tubes to a metallic module anchor. Flanges on the end of the tubes effectively lock the position of the tubes relative to the anchor at the time of installation.

Anchor-Loc ceramic fiber modules are manufactured in several configurations. A choice of attachment systems is provided to meet a wide range of application needs:

Weld-Loc® Ceramic Fiber Modules

A special weld assembly is installed in each Weld-Loc ceramic fiber module. This stud assembly permits fusion of the stud base to the furnace casing and allows a threaded fastener to be torqued on the stud, drawing the module to the casing plate. Advantages which are offered by the Weld-Loc module include:

- High installation speed
- Ease and simplicity of installation
- Permits random placement of modules on the casing
- Multiple welds per module are possible
- System provides a positive torque test of the welds

Power-Loc® Ceramic Fiber Modules

A hardened steel pin mechanically secures each Power-Loc module to the steel casing plate. The anchor pin is installed with a special Hilti® powder actuated fastening tool and powder booster. Advantages which are offered by the Power-Loc ceramic fiber module include:

- High installation speed
- Casing preparation is eliminated
- Permits random placement of modules on the casing
- Ease and simplicity of installation
- Positive mechanical attachment of modules to the casing plate
- Setup time is reduced

Hilti® is a trademark of Hilti Tool Corporation.

Anchor-Loc Modules are protected under U.S. patents #4,803,822 and 4,850,171.

Refer to the product Material Safety Data Sheet (MSDS) for recommended work practices and other product safety information.

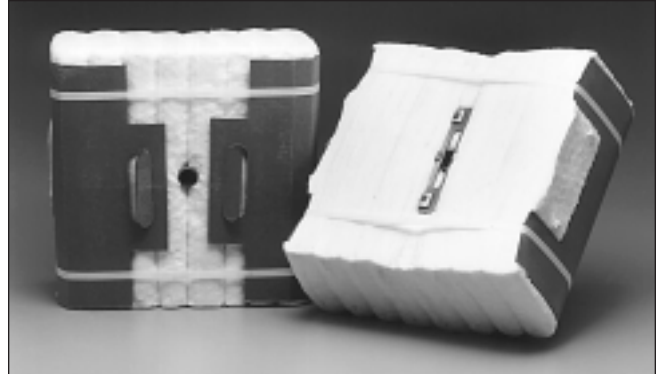

Thread Loc® Ceramic Fiber Modules

Provided with an all-thread weld stud and flanged nut, the Thread Loc ceramic fiber module is designed for installation on a prepositioned stud pattern. The Thread Loc attachment system has several advantages:

- Compatibility with mastic coatings, backup insulation, and foil vapor barriers
- Module design compensates for variations in stud placement
- Access to the welded fastener for full testing before the module is installed

Screw Loc® Ceramic Fiber Module

A self-tapping screw supplied with each Screw Loc ceramic fiber module easily penetrates mild steel up to ½" in thickness. The Screw Loc attachment system provides the following installation advantages:

- Multiple, random anchor placement
- Ease of removal and replacement
- Furnace casing preparation is eliminated
- Low cost installation equipment is readily available

Anchor-Loc ceramic fiber modules offer the same advantages as layered Fiberwall® furnace linings when compared to refractory construction. They are:

- Faster temperature cycling
- Lower heat storage
- Lower fuel costs
- Increased productivity
- Lower installed cost
- Easier repairs

Anchor-Loc Module Applications

- Stress relieving furnaces
- Annealing furnaces
- Carbottom heat treating furnaces
- Process heaters
- Reheat furnaces
- Furnace, kiln and boiler linings
- Incineration equipment and stack linings
- Soaking pit covers
- Ladle covers
- Ladle preheaters
- Forge furnaces

Typical Product Properties

Module Type	Temperature Grade	Recommended Operating Temperature
Anchor-Loc 2200	1260°C (2300°F)	1149°C (2100°F)
Anchor-Loc 2400	1316°C (2400°F)	1232°C (2250°F)
Anchor-Loc 2600	1427°C (2600°F)	1343°C (2450°F)
Anchor-Loc 3000	1649°C (3000°F)	1532°C (2800°F)

The recommended operating temperature of Fiberfrax products is determined by irreversible linear change criteria, not melting point.

Data are average results of tests conducted under standard procedures and are subject to variation. Results should not be used for specification purposes.

Typical Product Parameters

Available Anchor-Loc Ceramic Fiber Modules
 305 mm x 305 mm (12" x 12")
 305 mm x 152.5 mm (12" x 6")

Module	Construction	Module Density
Anchor-Loc 2200	Folded	128 kg/m ³ (8 lb/ft ³)
	Durablanket-S	160 kg/m ³ (10 lb/ft ³)
Anchor-Loc 2400	Folded	149 kg/m ³ (9.3 lb/ft ³)
	Durablanket HP-S	192 kg/m ³ (12 lb/ft ³)
Anchor-Loc 2600	Folded	149 kg/m ³ (9.3 lb/ft ³)
	Durablanket 2600	192 kg/m ³ (12 lb/ft ³)
Anchor-Loc 3000	Layered	96 kg/m ³ (6 lb/ft ³)
	Fibermax mat	128 kg/m ³ (8 lb/ft ³)

A. Weld-Loc® Attachment System

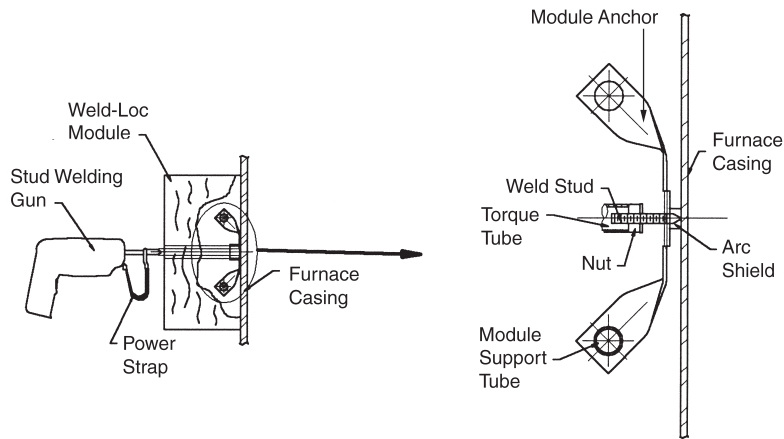

B. Power-Loc® Attachment System

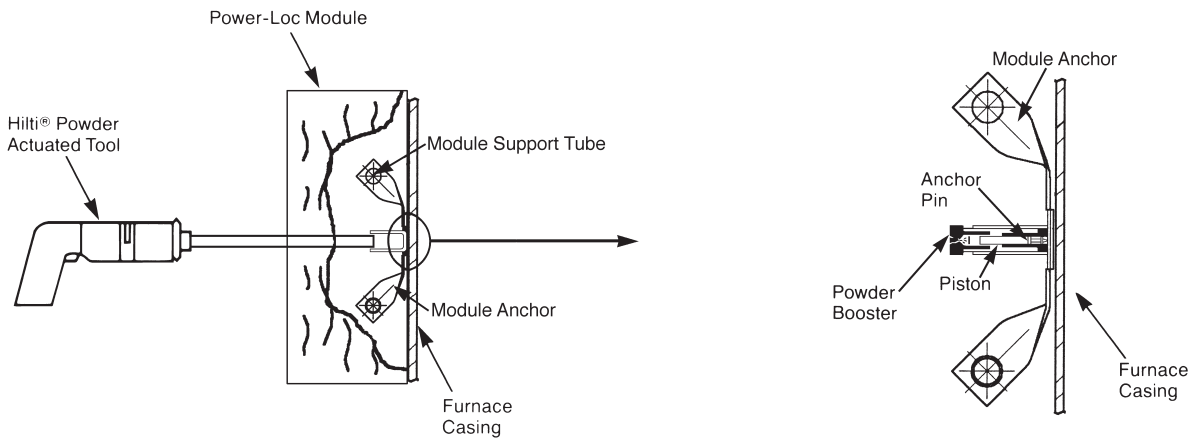

C. Thread Loc® Attachment System

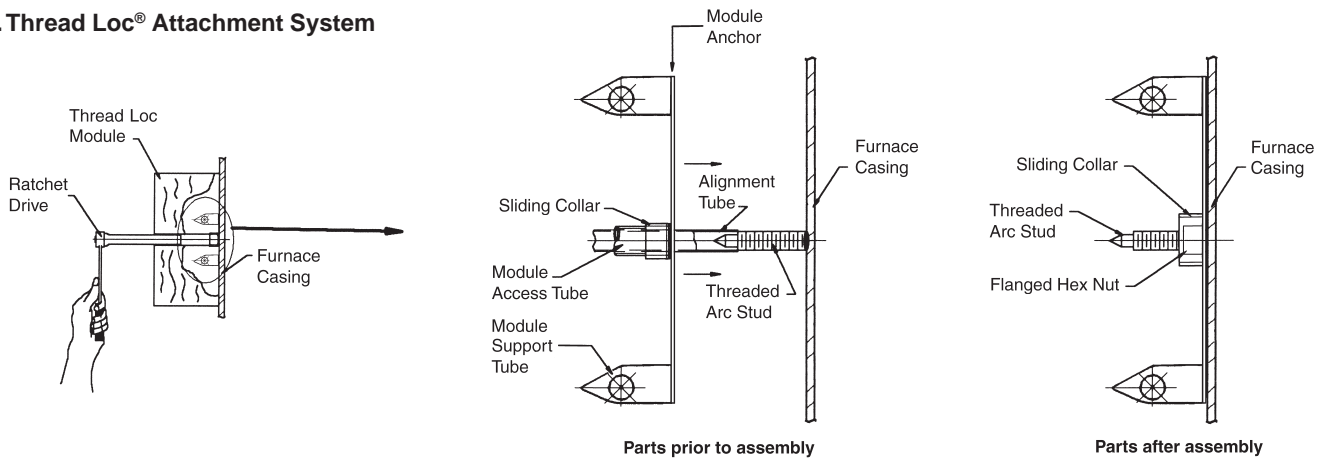

D. Screw Loc® Ceramic Fiber Module

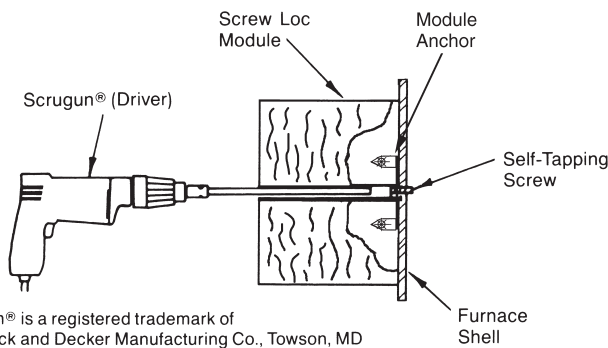

Anchor-Loc Modules

Anchor-Loc 2200 Modules – 128 kg/m³ (8 lbs/ft³)

Hot Face °C (°F)	Insulation Thickness – mm (in) Cold Face Temperature –	102 (4) °C (°F)	152 (6) °C (°F)	203 (8) °C (°F)	254 (10) °C (°F)
649 (1200)		76 (169)	62 (144)	54 (130)	50 (122)
871 (1600)		112 (233)	89 (193)	77 (170)	68 (155)
1093 (2000)		155 (311)	123 (254)	105 (221)	93 (199)

Anchor-Loc 2200 Modules – 160 kg/m³ (10 lbs/ft³)

Hot Face °C (°F)	Insulation Thickness – mm (in) Cold Face Temperature –	102 (4) °C (°F)	152 (6) °C (°F)	203 (8) °C (°F)	254 (10) °C (°F)
649 (1200)		72 (161)	59 (138)	52 (126)	48 (118)
871 (1600)		105 (221)	84 (183)	72 (162)	64 (148)
1093 (2000)		144 (291)	114 (238)	97 (207)	86 (187)

See note on bottom of next page.



Anchor-Loc 2400 Modules – 149 kg/m³ (9.3 lbs/ft³)

Hot Face °C (°F)	Insulation Thickness – mm (in) Cold Face Temperature –	152 (6) °C (°F)	203 (8) °C (°F)	254 (10) °C (°F)	305 (12) °C (°F)
982 (1800)		101 (214)	87 (188)	77 (170)	70 (158)
1093 (2000)		118 (244)	100 (212)	89 (192)	81 (177)
1204 (2200)		136 (276)	115 (239)	102 (215)	92 (197)

Anchor-Loc 2400 Modules – 192 kg/m³ (12 lbs/ft³)

Hot Face °C (°F)	Insulation Thickness – mm (in) Cold Face Temperature –	152 (6) °C (°F)	203 (8) °C (°F)	254 (10) °C (°F)	305 (12) °C (°F)
982 (1800)		95 (203)	81 (178)	72 (162)	66 (151)
1093 (2000)		109 (229)	93 (200)	83 (181)	75 (167)
1204 (2200)		125 (257)	106 (223)	94 (201)	85 (185)

Anchor-Loc 2600 Modules – 149 kg/m³ (9.3 lbs/ft³)

Hot Face °C (°F)	Insulation Thickness – mm (in) Cold Face Temperature –	152 (6) °C (°F)	203 (8) °C (°F)	254 (10) °C (°F)	305 (12) °C (°F)
1149 (2100)		126 (260)	108 (226)	95 (203)	86 (187)
1260 (2300)		145 (293)	123 (253)	108 (227)	97 (208)
1316 (2400)		154 (310)	131 (268)	116 (240)	104 (220)

Anchor-Loc 2600 Modules – 192 kg/m³ (12 lbs/ft³)

Hot Face °C (°F)	Insulation Thickness – mm (in) Cold Face Temperature –	152 (6) °C (°F)	203 (8) °C (°F)	254 (10) °C (°F)	305 (12) °C (°F)
1149 (2100)		117 (243)	99 (211)	88 (191)	80 (176)
1260 (2300)		133 (271)	113 (236)	100 (212)	90 (194)
1316 (2400)		141 (286)	120 (248)	106 (223)	96 (204)

Anchor-Loc 3000 Modules – 96 kg/m³ (6 lbs/ft³)

Hot Face °C (°F)	Insulation Thickness – mm (in) Cold Face Temperature –	152 (6) °C (°F)	203 (8) °C (°F)	254 (10) °C (°F)	305 (12) °C (°F)
1316 (2400)		170 (338)	145 (293)	128 (262)	115 (239)
1427 (2600)		189 (372)	161 (322)	142 (288)	128 (262)
1538 (2800)		208 (406)	178 (352)	157 (314)	142 (287)

Anchor-Loc 3000 Modules – 128 kg/m³ (8 lbs/ft³)

Hot Face °C (°F)	Insulation Thickness – mm (in) Cold Face Temperature –	152 (6) °C (°F)	203 (8) °C (°F)	254 (10) °C (°F)	305 (12) °C (°F)
1316 (2400)		155 (311)	132 (270)	117 (242)	106 (222)
1427 (2600)		172 (342)	147 (296)	129 (265)	117 (242)
1538 (2800)		189 (373)	162 (323)	143 (289)	129 (264)

All heat flow calculations are based on a surface emissivity factor of .90, an ambient temperature of 27°C (80°F) and zero wind velocity, unless otherwise stated.

All thermal conductivity values for Fiberfrax materials have been measured in accordance with ASTM Test Procedure C-177. When comparing similar data, it is advisable to check the validity of all thermal conductivity values and ensure the resulting heat flow calculations are based on the same condition factors. Variations in any of these factors will result in significant differences in the calculated data.

For additional information about product performance or to identify the recommended product for your application, please contact the Unifrax Application Engineering Group at 716-278-3888.

Data are average results of tests conducted under standard procedures and are subject to variation. Results should not be used for specification purposes.

